

In the best amateur tradition, W5GI has designed a multiband wire antenna that confounds the antenna modeling software, but passes the most important test of all: It works ... well.

The W5GI Multiband Mystery Antenna

BY JOHN P. BASILOTTO,* W5GI

This article describes an antenna that covers 80 to 6 meters with low feed-point impedance and that will work with most radios, with or without an antenna tuner. It is approximately 100 feet long, can handle the legal limit, and is easy and inexpensive to build. It's similar to a G5RV but a much better performer, especially on 20 meters. During the last two-plus years the antenna described herein was built, installed, and used by amateurs at various heights and configurations in over 300 locations. Feedback from users indicates that the antenna met or exceeded all performance criteria. The "mystery" part of the antenna comes from the fact that it is difficult, if not impossible, to model and explain why the antenna works as well as it does.

*808 Mariner, Austin, TX 78734
e-mail: <w5gi@aol.com>

Over two years ago I moved to a new QTH. Like many other amateurs, I succumbed to my wife's demands, which also meant living in a community that prohibits towers and most antennas. Fortunately, the lot we purchased has two large oak trees about 130 ft. apart, which allowed installation of wire antennas at about 25 ft. above ground. I initially installed a G5RV because I work mostly 17, 20, and 40 meters and had good luck with it on these bands at other locations. Although the G5RV worked well, it did not provide the performance I had hoped for.

Over a period of several months I tried a variety of popular antennas—full-size loops for 80 and 40 meters, a commercial multiband dipole, resonant dipoles, a multiband vertical, half square, extended Zepp, and a 130 ft. dipole fed with open-wire line. Each antenna worked reasonably well, but I still wasn't satisfied. In my quest to find a better

antenna, I came across an article by James E. Taylor, W2OZH, in which he described a low-profile collinear coaxial array.¹ It was Taylor's article that inspired my design.

The W5GI Multiband Mystery Antenna is fundamentally a collinear antenna comprising three half waves *in-phase* on 20 meters with a half-wave 20 meter line transformer. It may sound like and look like a G5RV, but it is a substantially different antenna on 20 meters. Louis Varney's antenna, although three half waves long, is an *out-of-phase* aerial. Mr. Varney (G5RV) had very specific reasons for selecting a three-half-wave arrangement on 20: He wanted a four-lobe radiation pattern, at least unity gain, and a low feed-point impedance.² On the other hand, I wanted a six-lobe pattern on 20 meters, gain broadside to the antenna, and also low feed-point impedance to simplify matching the antenna to the rig. In addi-

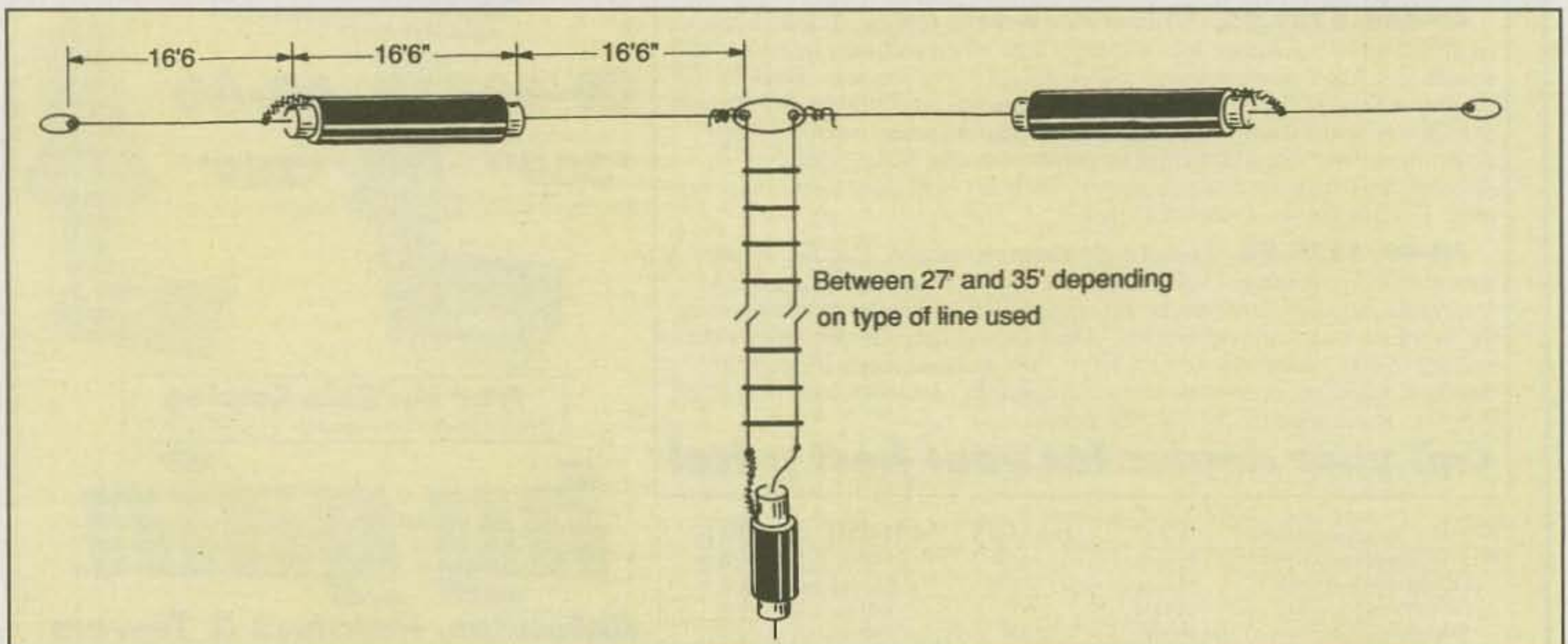

Fig. 1—Schematic drawing of the W5GI Multiband Mystery Antenna. See text for details on connection of coax sections in center of antenna legs and on length of twinlead stub.

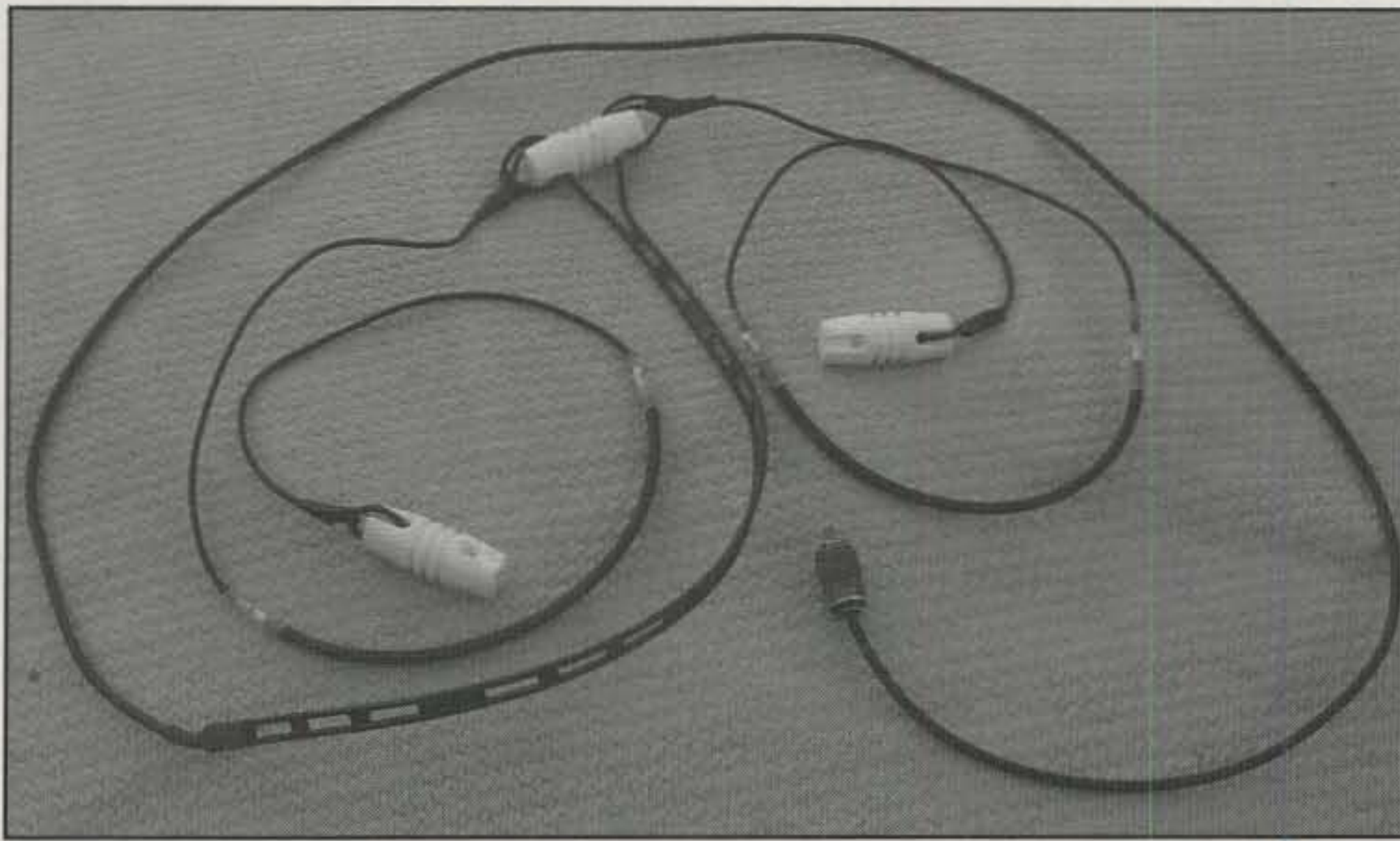

Photo A— Full view of the W5GI Multiband Mystery Antenna, with all sections shortened considerably for illustration.



Photo B— Connection of inner end of coax section (closer to center). Note that only the center conductor is connected to the wire.

tion, the antenna had to be usable as a G5RV and work at least as well on the other HF bands. The answer to my needs was a skywire that incorporated the advantages of a 3-element collinear and the G5RV antenna.

In its standard configuration, a collinear antenna uses phase reversing stubs added at the ends of a center-fed dipole. These stubs put the instantaneous RF current in the end elements in phase with that in the center element. You can make these phase-reversing stubs from open-wire line or coaxial cable. Normally, a shorted quarter-wave stub is used, but an open-ended half-wave stub would also work. The problem is that the dangling stubs are unwieldy and/or unsightly.

In his article Taylor described a low-profile collinear coaxial array. According to Taylor, when you apply an RF voltage to the center conductor at the open end, the stub causes a voltage phase lag of 180 degrees at the adjacent coax shield. This happens because the RF is delayed by one quarter-cycle as it passes from left to right,

inside the coax to the shorted (opposite) end. There's another quarter-cycle delay as the wave passes back from right to left inside the coax and emerges on the shield at the open end. Add up the delays and you get a total time delay of one-half cycle, or 180 degrees. In essence, the coax section serves two purposes: It provides the necessary delay and provides part of the radiating element in a collinear array.

My initial version of the antenna used the Taylor formulas, cutting the wires to a quarter wave length using $234/f(\text{MHz})$ and cutting the coax sections using the same formula, but adjusting the lengths to compensate for the velocity factor of the specific cable used. The first version of my antenna worked well on 20 meters but failed as a multi-band antenna.

I built a second antenna, but this time I cut the coax to the same length as the wire. My reasoning was that perhaps the coax didn't behave like coax and therefore the velocity factor wasn't applicable. To my amazement, the new antenna performed exceptionally well on 20 meters, had low SWR, and per-

Installation data

wire: 14 AWG
 coax: Mini 8X
 Ladder-line: Cut to half wave length at 20 meters using appropriate velocity factor

Performance (measurements taken with MFJ 259 Analyzer)

Freq.	SWR	R	X
3550	1.5	42	34
3650	2.5	98	61
3850	3.5	48	61
3950	4	22	36
7000	1.9	95	12
7200	3	22	25
10.1	5.2	22	50
14	1.7	37	19
14.2	1.5	42	18
14.3	1.6	43	22
18.15	1.9	93	13
21.3	2.9	120	46
24.9	1.9	35	23
27.8	2.1	26	16
28.35	1.8	33	20
29.5	2.6	53	55
50.11	2.3	51	37
52.5	1.2	57	7

Table 1— Measured performance of the W5GI Multiband Mystery Antenna at various frequencies. Columns list frequency, SWR (all as a ratio to 1), Resistance (R) in ohms, and Reactance (X) in ohms.

formed just as well as my G5RV reference antenna on the other HF bands and 6 meters.

Step-by-Step Construction

The W5GI Multi-band Mystery Antenna looks like a plain dipole (fig. 1 and photo A) and is very simple to build. You will need three wish-bone insulators, about 70 ft. of wire (14-gauge household electrical wire works well), enough twin lead or open wire to make a half-wave section on 20 meters (I found that window-type, 18-gauge, 300 ohm ribbon works best³), 34 ft. of RG-8X mini-coax, an electrical connector⁴ to connect the twin lead and coax, and shrink tubing to cover the exposed coax joints. The antenna can be built in less than an hour when you have the above materials.



Photo C— Connection of outer end of coax section (farther from center). Note that both center conductor and shield are connected to the wire.

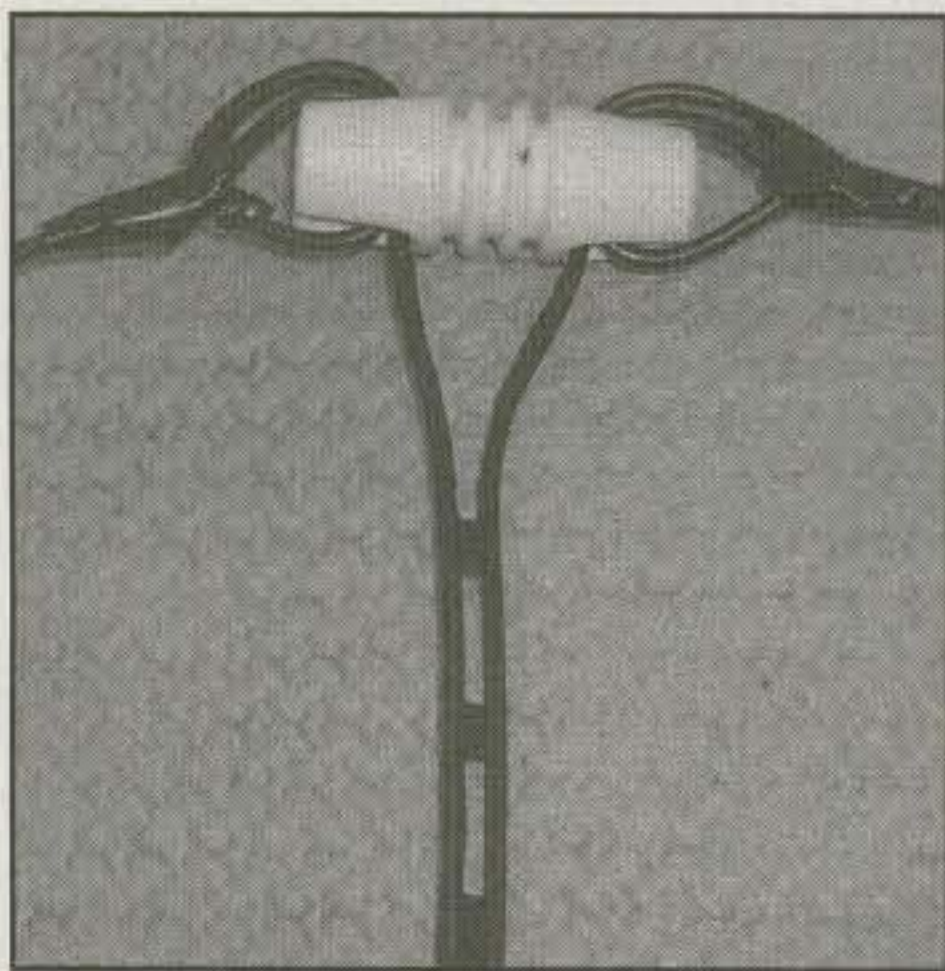

Photo D. Connection of twinlead to inner antenna wires at center of antenna.

When you're ready to proceed, do the following:

- Cut the electrical wire into four equal lengths of 17 ft.
- Cut the two lengths of coax to 16 ft. 6 in. each.
- Cut a 20 meter half-wave section of twin lead. This piece needs to be adjusted by its velocity factor. I used 300 ohm window-type line with a VF of .91, for a total length of 30 ft. 450 ohm, solid 300 ohm, or homemade open-wire line can be used provided the electrical length is one-half wave at 20 meters. Actual length obviously will vary, typically be-

tween 27 and 35 ft., depending on type and velocity factor.

- Trim 2 in. of braid from one end of both lengths of coax (item A).
- Trim 1 in. of braid *and* center insulator from the opposite end of both coax sections (item B).
- Build a 20 meter dipole without end insulators.

The next two steps of the construction process involve connecting only the "inner" end section of the coax section to one end of the dipole; the shield is not connected to anything here. At the other end of the coax section both the coax shield and second wire section are connected to the coax center conductor.

- Connect one end of the dipole to the center conductor of the coax (item A) and cover with shrink tubing (photo B).
- Connect the opposite end of the coax (item B) to braid *and* quarter-wave wire section, cover with shrink tubing, and connect to end insulator (photo C).
- Install the twin lead through the holes of the center insulator (you may have to enlarge the holes) and solder to antenna wire (photo D).
- Connect the opposite side of the twin lead to the coax (photo E). Almost any type of connection will work, provided the connection is stable and sealed properly. The coax length in the photo is for illustration only. It should be long enough to reach your radio!
- Install the antenna with the center

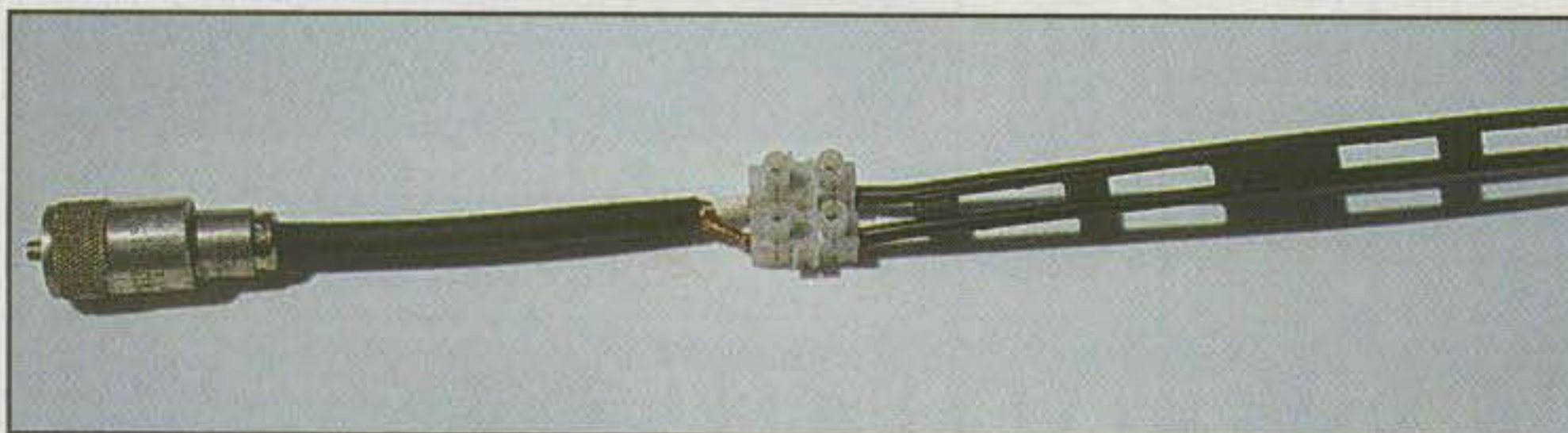

Photo E— Connection of twinlead to coax. Short length of coax section is for illustration only. All connections should be weatherproofed with shrink-tubing, CoaxSeal®, or similar.

conductor at least 25 ft. high. Mine is installed in a horizontal plane; however, others have installed the 'GI antenna as an inverted-Vee and are getting excellent results. Table I shows the typical SWR results for this antenna.

On-The-Air Performance

On 20 meters you should expect 3–6 dB gain over a dipole and a six-lobe radiation pattern with an elongated figure-8 pattern perpendicular to the plane of the antenna. This is typical of a 3-element collinear array.⁵ On all other bands the antenna performs like a G5RV, which is really a random-length dipole on all but 20 meters. M. Walter Maxwell, in *Reflections II, Transmission Lines and Antennas*, aptly describes this phenomenon. Several users report it is possible to use the antenna on 160 meters, but you will need to connect the twin lead together at the point where it connects to the coax. On 160 the antenna performs like a Marconi. Those who have used the antenna on 160 say the "GI Mystery Antenna" is a quieter receiving antenna compared to other 160 meter antennas.

As for the theory of operation, it remains a mystery. At least three "experts" tried computer modeling the antenna. All three rendered completely different findings. I hope to have more sophisticated findings at a later date. In the meantime, enjoy what for many has been a fun project and an excellent performer.

In conclusion, I would like to thank the many amateurs who have built and used this antenna during the last couple of months, especially Dean, N9ZLS, who personally built over a dozen GI Mystery Antennas and whose feedback has been invaluable; Rod, WA9GQT, who uses the antenna in QRP operation with impressive results, for his feedback regarding 160 meters; and last, but not least, my wife, who provided the opportunity and encouragement to build the *W5GI Multi-band Mystery Antenna*.

Notes

1. James E. Taylor, "COCOA-A Collinear Coaxial Array," *73 Amateur Radio*, August 1989: 24.
2. M. Walter Maxwell, *Reflections II Transmission Lines and Antennas*, Worldradio Books 2001: 20-10.
3. Available from the Wireman and other sources.
4. Available from most electrical parts outlets.
5. For a simple explanation of collinear arrays, read *Troubleshooting Antennas and Feedlines* by Ralph Tyrrell, W1TF.